



F50AI
Shown

Features

- **Pump Design** – Compact, close coupled
- **Pump End** – Lightweight design
- **Cost** – Economical design

Applications

- Air Conditioning
- Washing Machines
- Carpet Cleaners
- Bilge Pumps
- Filter Systems
- Brine Circulation
- Circulation / Filtration
- Coolant Pumps

Optional Configurations

- **Power Frame Mounting:**

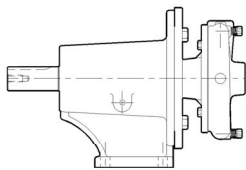

- **Long-Coupled Mounting:**

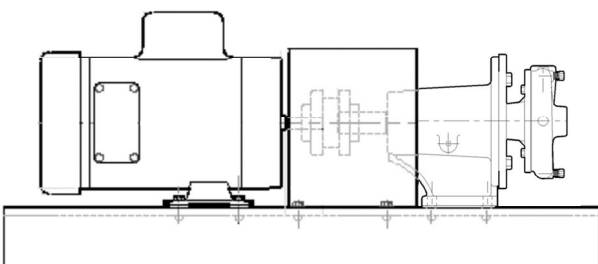

F50/75/95

Pump Volute / Impeller Materials

- F (AI) – Cast Iron / Cast Iron
- F (BF) – Cast Iron / Bronze
- F (AB) – Bronze / Bronze

Standard Specifications

- F50 Discharge 1/2" FNPT, Suction 3/4" FNPT
- F75 Discharge 3/4" FNPT, Suction 1" FNPT
- F95 Discharge 1" FNPT, Suction 1-1/4" FNPT
- Maximum Impeller Diameter: 3.94"
- Motor Shaft: 416SS
- Motor: NEMA 56J Footless (Multiple enclosures available)
- Mechanical Seal:
 - Single, 5/8" Type 6A Buna, Carbon vs. Ceramic
 - Note: Additional seal options available*
- Gasket: Synthetic Fiber

Performance Curve – 60 Hz

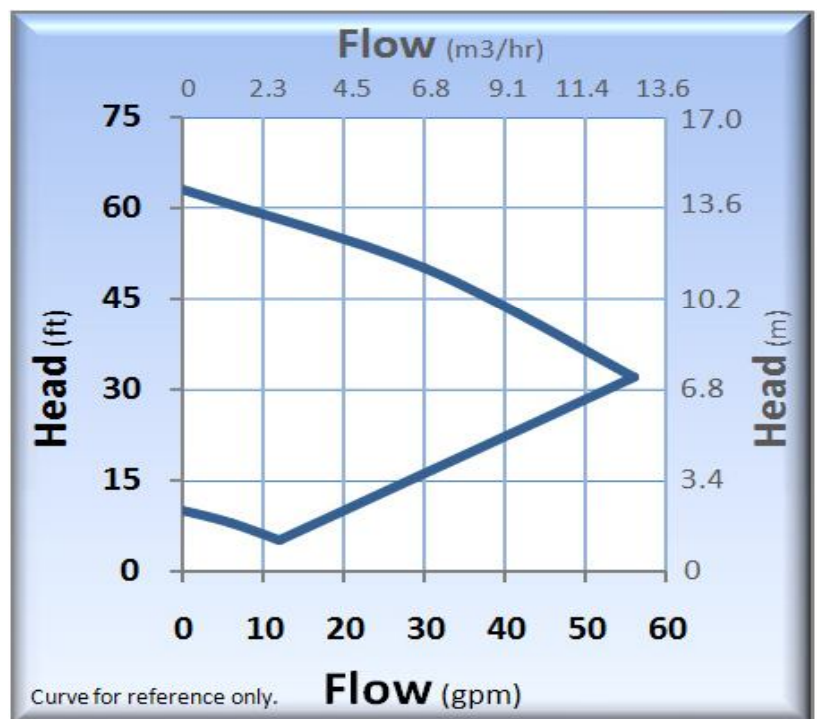

F50/75/95

Technical Information	
Max Flow	55 GPM (12.5 m3/hr)
Max Head	63 feet (19.2 m)
Min. Flow	5 GPM (1.1 m3/hr)
Max Solid Size	0.150" (3.81 mm)
Max Working Pressure	(Type 6A Seal) 75 PSI (5.2 bar) (Type 9 Seal) 350 PSI (24.1 bar) (Type 21 Seal) 150 PSI (10.3 bar)
Max Temp.	200°F (93°C)*

Materials of Construction			
Type F	AI	BF	AB
Volute	Cast Iron	Cast Iron	Bronze
Impeller	Cast Iron	Bronze	Bronze
Bracket	Cast Iron	Cast Iron	Bronze
Gasket	Syn. Fiber	Syn. Fiber	Syn. Fiber
Fasteners	Plated Steel	Plated Steel	18-8 SS

* Temperature limits are based on standard seal and gasket materials, and will vary according to the liquid being pumped.

Dimensions (F50/75/95)

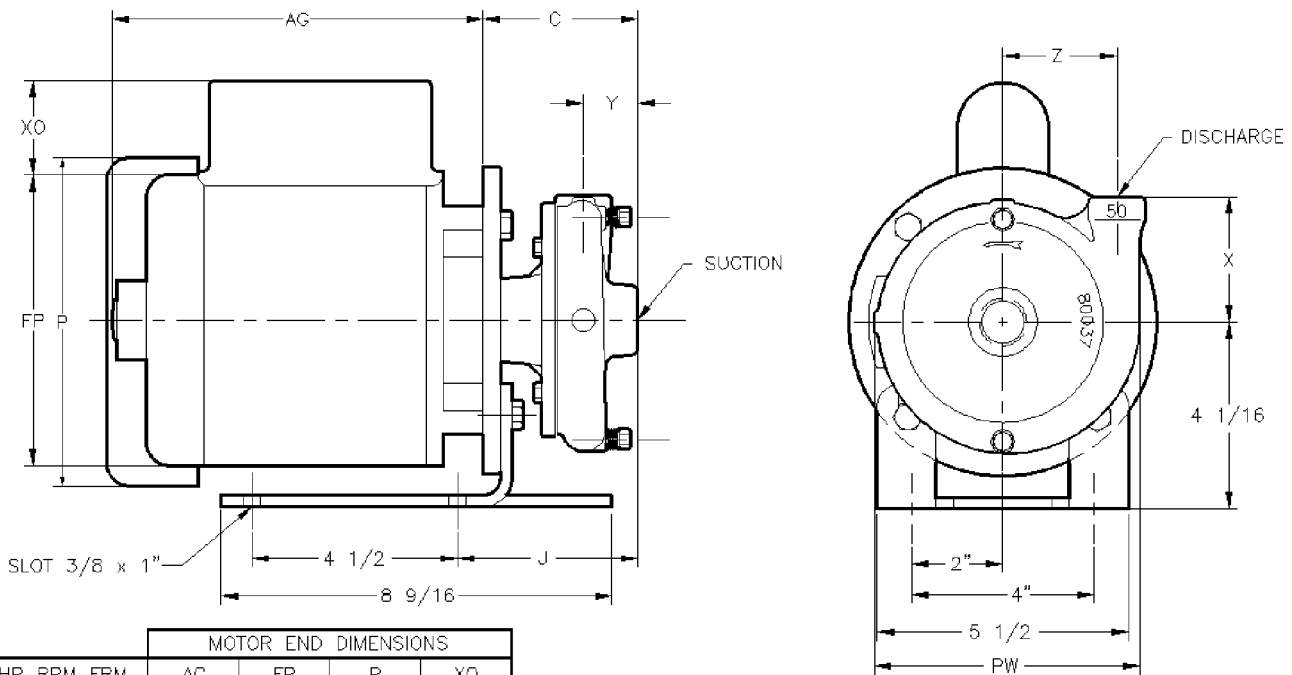

MOTOR END DIMENSIONS				
HP	RPM	FRM	AG	X0
1/3	3600	56J	8 3/4	2 1/4
1/2	3600	56J	8 3/4	2 1/4
3/4	3600	56J	9 1/8	2 1/4
1	3600	56J	9 3/4	2 1/4
1 1/2	3600	56J	10 1/4	2 1/4
2	3600	56J	10 3/4	2 1/4

NOTE:
MOTOR DIMENSIONS WILL VARY BY MODEL AND MAKE.
DIMENSIONS ARE TO BE USED FOR REFERENCE ONLY.
ALL DIMENSIONS ARE ROUNDED TO THE NEAREST 1/8".

MODEL	PUMP END DIMENSIONS						THREADED NPT		
	C	DD	PW	J	X	Y	Z	DISCH.	SUC.
F50	3 3/8	2 7/8	5 13/16	3 15/16	2 3/4	1 3/16	2 1/2	1/2"	3/4"
F75	3 11/16	2 15/16	6 1/4	4 1/4	3 1/4	1 1/2	2 1/2	3/4"	1"
F95	3 11/16	2 15/16	6 1/4	4 1/4	3 1/4	1 1/2	2 1/2	1"	1 1/4"



Contact factory for special pump configurations,
same day, and next day delivery options.



21775 Eighth Street East
Sonoma, CA 95476-0329
MAIN (707) 938-8441
TOLL FREE (800) 345-7867
FAX (707) 938-0764
E-mail: sales@pricepump.com
Website: www.pricepump.com



Rev. Date: May 2009